



“SPIN-ON”

High Pressure Fuel Air Separator

INSTALLATION MANUAL

For Detroit Series 60 Engines

Equipped with a Spin-On Secondary Fuel Filter Housing



**PLEASE READ
THESE INSTRUCTIONS
THOROUGHLY
BEFORE BEGINNING
INSTALLATION**



Part No. A7SODE730



Proudly Made in the USA

Revised 10/18/22

www.airdogdiesel.com

1-573-635-0555 or

1-877-463-4373

Providing “Test Cell Performance” in “Real World Conditions” Since 1993

PATENT

www.AirDogDiesel.com/patents



HEAVY DUTY & INDUSTRIAL
Fuel Systems
by **PureFlow**[™]
Technologies, Inc.

Amazingly Simple Installation

Spins on between filter head and the fuel filter. Air/Vapor return line connects to engine fuel return line.

Amazingly Simple Operation

Operates in conjunction with the fuel flow and pressure created by the engines transfer pump. Separates and removes entrained air plus vapor from fuel pump cavitation before the fuel enters the engine.



The AirDog[®] Champ II is proudly made in the USA.



With PureFlow Technologies AirDog[®] Champ II system installed, your diesel engine can perform as designed even under the most extreme conditions.

877-GO-DIESEL (877-463-4373)
airdogdiesel.com

- ◆ Improves Fuel Mileage
- ◆ Lengthens Injector Life
- ◆ Smoother Idle
- ◆ Improves Throttle Response
- ◆ Maximizes Torque
- ◆ Reduces Emissions



Proudly made in the USA

TABLE OF CONTENTS

Section 1.....Table of Contents
 Section 2.....Installation and Safety Guidelines
 Section 3.....Parts List
 Section 4.....System Overview

INSTALLATION PROCEDURES

Section 5.....Installing the AirDog® Champ II
 Section 6.....Installing the Air/Vapor Return Line

OPTIONAL DETROIT SECONDARY FUEL SYSTEM UPGRADE

Section 7.....Fuel System Upgrade
 Section 8.....Initial Start-Up Procedure

MAINTENANCE

Section 9.....Filter Service

Section 2: INSTALLATION GUIDELINES

The installation of your AirDog® Champ can be made relatively easy by following the steps outlined in this manual, and:

1. Inventory the package components. Notify PureFlow® Technologies, immediately of any missing or damaged parts.
2. Read the installation manual completely. Understand how the system operates and the installation recommendations before beginning.

SAFETY GUIDELINES

CAUTION: Chock the vehicle’s tires to prevent rolling.



CAUTION: Wear safety glasses when operating power tools such as drills and grinders or when using a punch or chisel.

CAUTION: Route the fuel lines and electrical harnesses keeping them away from hot exhaust components and/or moving parts. Properly secure the fuel lines and electrical harnesses to prevent chafing.

If you are uncertain of any installation procedure, contact PureFlow® Technologies, Inc. for technical assistance.

NOTE: The pictures used in this manual are for example only and may not depict the exact components as found on your truck.

Installation Parts List

| QTY | Description | Part Number | Image |
|-----|--|---------------|---|
| 1 | Installation Manual | 207-7-0730 |  |
| 1 | AirDog® Champ II High Pressure Air Separator | CHPII-730-WIP |  |
| 1 | AirDog® Fuel Filter | FF200-MG-6 | |
| 1 | #6 Hose w/end fittings 7' L Hose Assembly | 4C-1-06-06-84 |  |

970-07-0730 Installation Fitting Kit

| | | | |
|---|--|------------------|---|
| 1 | #6M JIC x 3/8 M ORB 90° Elbow | 4A-2-01-06-06-S |  |
| 1 | #6M JIC x 1/4 M NPTF Straight Connector | 4A-1-01-A-C-SZ |  |
| 1 | #8M JIC x #8F JICX x 1/4 NPTF Port GagePort | 4A-1-11-08-08-4P |  |
| 1 | #6M JIC x 3/8 F NPTF Straight Connector (Return Fitting) | 4A-1-04-06-06-S |  |
| 1 | 3/8 M SAE x 3/8 M SAE x 3/8 M NPTF Tee | 4A-4-08-06-06-B |  |
| 1 | #6F SAEX x #6F SAEX Union Swivel | 4A-1-22-06-06-B |  |

Section 4: System Overview

PureFlow® Technologies, Inc. addresses diesel engine efficiency and peak performance on the fuel side, from the fuel tank to the tip of the injector. Removing entrained air and fuel vapor from the fuel flow to the engine is not enough if the internal conditions of the fuel system components are such to allow vapor to form in the injector itself.

Specifically, if the fuel pressure/flow to the injector, even with entrained air and vapor removed, is insufficient to totally fill the injector barrel on the up stroke of the plunger, a void or low pressure will form that allows vapor to re-form within the injector. The result, “injector lag”, is just another name for “delayed injection timing”. No matter what term is used, it leaves the engine with increased fuel consumption, lost power, and increased exhaust emissions.

To overcome these concerns, PureFlow® Technologies has an “Upgrade Kit” available for the Detroit Series 60 Engine. The **“Upgrade” kit is NOT included** with the Champ II installation kit, although the complete and detailed instructions are included.

Contact PureFlow® Technologies at 1-573-635-0555 for additional information and ordering.

Section 5: Installing the AirDog® Champ II

NOTE: Figure 1 is showing the secondary fuel filter mounted on a 2005 Detroit Series 60.



Figure 1

5-1. Remove the Detroit secondary fuel filter. (Figure 1)
5-2. Check the O-ring seal to be sure that it is properly installed in the “Groove” in the top of the Champ II. (Figure 2)



Figure 2

5-3. Screw the Champ II onto the Detroit secondary fuel filter head. (Figure 3)



Figure 3

NOTE: The Champ II is a “spin-on” unit and once it has been tightened we cannot determine the accessibility of the Air/Vapor return port. Therefore, we have machined two Air/Vapor return ports into the Champ II approximately 120° apart. One or the other air/vapor return port will be accessible after tightening the Champ II.

5-4. After tightening the Champ II, remove the 3/8” ORB plug from the most accessible air/vapor return port. (Figure 4)

Figure 4

Remove Plug

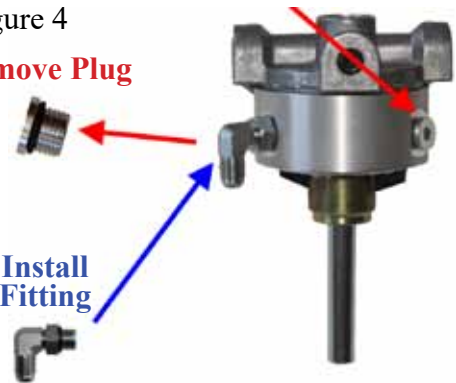

Install Fitting

5-5. Install the 3/8” ORB x #6 JIC 90° elbow fitting into the air/vapor return port. (Figure 4)

Section 6: Installing the Champ II Air/Vapor Return Line

The AirDog® Champ II returns entrained air & vapor to the fuel tank. It is best to connect the Air/Vapor return line directly to the engine fuel return line. Be sure to connect it after the pressure regulator. (Figures 5 & 6)

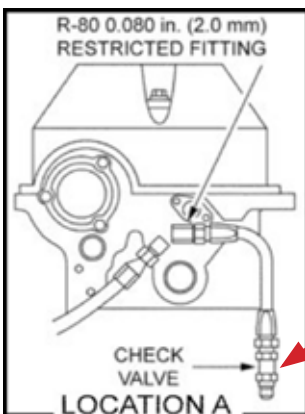

VERY IMPORTANT: The AirDog® Champ II Air/Vapor return “T” must be installed after the Detroit Regulator/Check Valve. The valve may be attached to the 90° fitting on the back of the head (B) OR after a section of fuel line (A).

Figure 5

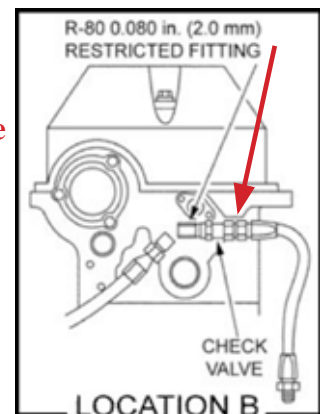

Figure 6

Section 6: Installing the Champ II Air/Vapor Return Line, cont'd

Air/Vapor Return Tee on the 1987-2002 Series 60



Figure 7

6-1. Disconnect the fuel return line connected to the pressure regulator at the back of the Series 60 head. (Figure 7)

6-2. Assemble the AirDog® Champ II Return Tee and install it on the outlet side of the Detroit Check Valve. Reconnect the original engine return line to the Tee. (Figure 8)

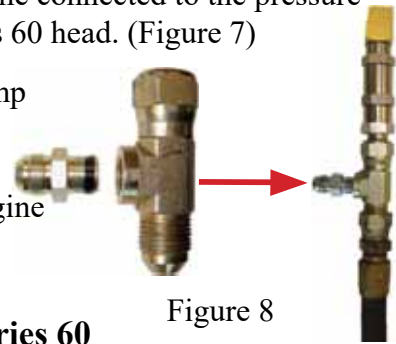

Figure 8

Air/Vapor Return Tee on the 2003-2009 Series 60

6-3. Disconnect the fuel return line connected to the pressure regulator at the back of the Series 60 head. (Figure 9)



Figure 9



Figure 10



Figure 11

6-4. Assemble the AirDog® Champ II Return Tee (Figure 10) and install it on the outlet side of the Detroit check valve. (Figure 11)



Figure 12

6-5. Reconnect the original engine return line to the #8 JIC fitting on the Tee. (Figure 12)

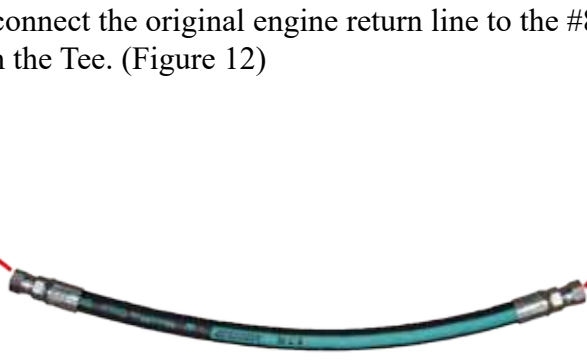

Figure 13



Figure 14

6-6. Connect one end of the Air/Vapor return line (Figure 13), included in the installation kit, to the Air/Vapor return fitting on the Champ II. (Figure 14)

Connect the other end to the #6 JIC on the Return Tee. (Figure 12)

6-7. Pre-fill the fuel filter with clean fuel and install it on the Champ II.

**Section 7: OPTIONAL AirDog® Detroit Series 60 Fuel Line Upgrade
OR continue on to page 10 for start-up procedure...**

Optional Kit available from PureFlow Technologies, Inc. - this kit is NOT included but recommended for optimal fuel system performance.

The Detroit Diesel Series 60® engine utilizes “FOR-SEAL” fittings with steel lines on the high pressure side of the transfer pump. These fittings have small passageways and are restrictive to the fuel flow to the engine. To maximize the efficiency of the Series 60® engine, it is necessary to replace the restrictive fuel fittings and lines with the larger and less restrictive lines & fittings. (Figure 15)



Figure 15

7-1. Disconnect and remove the steel fuel line from the “FOR-SEAL” fuel fitting at the fuel “OUT” port on the transfer pump and from the secondary fuel filter, fuel in port. (Figures 16 & 17)



Figure 16

7-2. Replace the “FOR-SEAL” fitting in the transfer pump with the “Ported” 16mm ORB x #8 JIC fitting **OR** the “Ported” 1/4” M NPT x #8 M JIC fitting. (Figure 18)



Figure 17

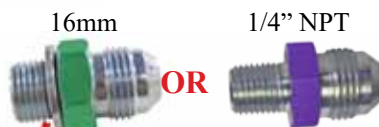

Figure 18



Figure 19

7-3. Replace the “FOR-SEAL” fitting in the secondary filter with the “Ported” 14mm x #8 JIC fitting **OR** the “Ported” 1/4” M NPT x #8 M JIC fitting. (Figure 19)

Section 7: OPTIONAL AirDog® Detroit Series 60 Fuel Line Upgrade

7-4. Measure and cut the length of the fuel line required to connect the transfer pump fuel “OUT” port to the secondary filter fuel “IN” port.

7-5. Assemble the fuel line with one straight and one 90° field attachable fuel line end fitting, as illustrated in Figure 21.

7-6. Attach the straight end to the transfer pump “OUT” port (Figure 20) and the 90° end to the secondary fuel filter.



Figure 20

7-7. Disconnect and remove the steel fuel line and shut-off valve from the secondary fuel filter outlet. (Figure 23)

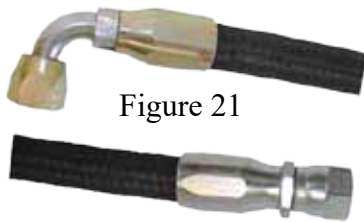

Figure 21

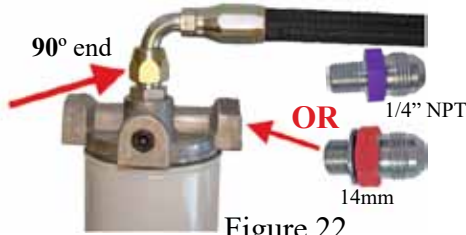

Figure 22

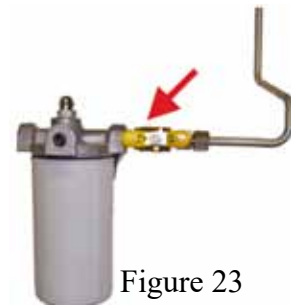

Figure 23

7-8. Install the “Ported” 14mm x #8 JIC fitting **OR** the “Ported” 1/4” M NPT x #8 M JIC fitting in the Out to Engine port. (Figure 22)

7-9. Disconnect the OE fuel supply line from the “FOR-SEAL” fuel inlet fitting at the back of the head. Remove the steel line and fitting. (Figure 24)

7-10. Install the 90° extended 3/8” NPT x #8 JIC fitting into the fuel in port vacated by the “FOR-SEAL” fitting. Use diesel fuel compatible thread sealer on all NPT threads. (Figure 25)



Figure 24



Figure 25



Section 7: OPTIONAL AirDog® Detroit Series 60 Fuel Line Upgrade

7-11. Measure and cut the length of fuel line required to connect the secondary filter “OUT” port to the 90° #8 JIC fitting just installed in the back of the engine head. (Figures 26 & 27)

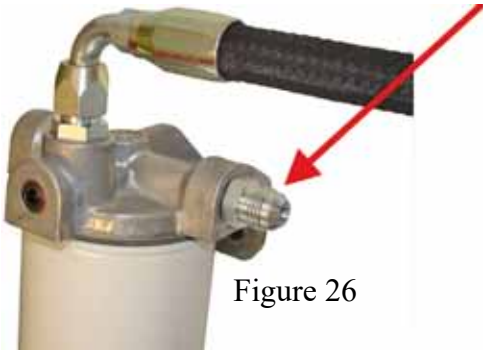

Figure 26

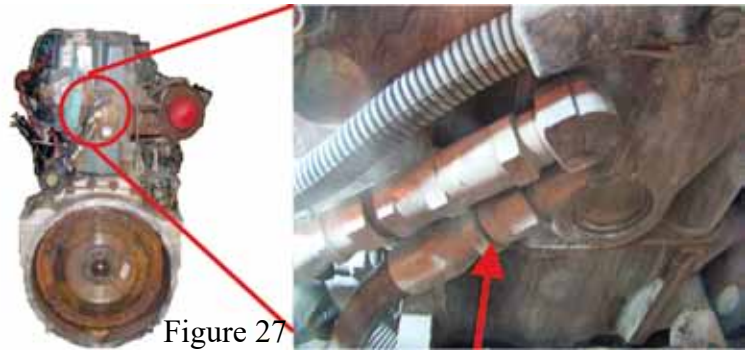

Figure 27

7-12. Assemble the fuel line with a straight field attachable fuel line end fitting on each end. (Figure 28)



Figure 28

7-13. Connect one end of the new fuel line to the fuel “OUT” port on the secondary fuel filter. Route and connect the other end to the #8 JIC fuel fitting in the head. (Figures 29 & 30)

7-14. Properly tighten all the fuel line connections and fittings. Secure the fuel lines with the included zip ties to prevent chafing.

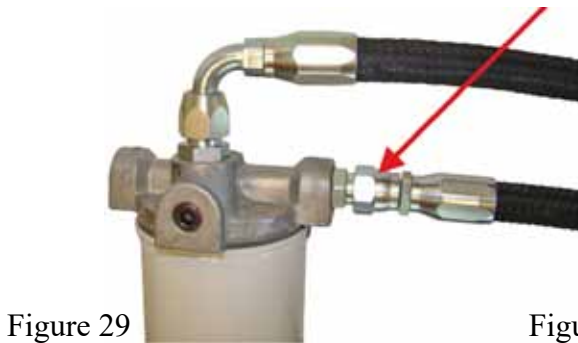

Figure 29



Figure 30

Section 8: Initial Start-Up Procedure

Be sure the secondary fuel filter is pre-filled with **CLEAN** diesel fuel **TO THE BOTTOM OF THE “NUT PLATE”**.

- 8-1. Rub **CLEAN** diesel fuel or oil on filter seals before installing to ensure a proper seal.
- 8-2. Pre-fill the fuel filter with diesel fuel to the bottom of the nut plate and install the filter.
- 8-3. Start your engine.
- 8-4. Bleed the fuel line to the engine by slightly loosening the fuel line connection at the engine fitting. As soon as the line is purged of air, tighten the fuel fitting.

NOTE: Put a rag or shop towel over and around the fitting to prevent fuel splatter or spray. Catch all spilled fuel and dispose of properly. Wear safety glasses.

RECHECK ALL FUEL FITTINGS FOR LEAKAGE AND PROPER TORQUE. BE SURE ALL LINES ARE PROPERLY ROUTED TO PROTECT FROM EXCESSIVE HEAT AND SECURED TO PROTECT FROM CHAFING AND ABRASION.

Section 9: Servicing the AirDog® Champ II Fuel Filter

The AirDog® fuel filters have a typical lifespan of 25,000+ miles, and up to 40,000 miles, as they are made with a high-quality and high-capacity Micro-glass media, as opposed to a paper element, and filter life is affected by many variables. In any case, we do not recommend exceeding 40,000 miles of service with a fuel filter. It is recommended that you keep a replacement AirDog® fuel filter on-hand, ready for replacement. When replacing the fuel filter, be sure to clean the under side of the Champ II base. Rub clean diesel fuel or oil on filter seal before installing to ensure a proper seal. Follow the instructions on the filter for proper tightening procedures.



*AirDog® Champ II
Fuel Filter
6 Micron Micro Glass*

*Built in Check Valve
Prevents fuel from
draining from the engine
head during filter changes*

NOTE: Due to the fact that fuel filters are often **OVER TIGHTENED** and difficult to remove, it is suggested to **carry a second filter wrench** to use as a backup wrench when changing the fuel filter.

Dispose of waste fuel and used filters properly to protect our environment.



www.airdogdiesel.com
1-877-463-4373 or
1-573-635-0555

Copyright© 2016
CD Patents, LLC

Bulletin No. 207-7-0730B
Revised May 07, 2024

All Rights Reserved